



## betterBRACE Installation Guide New Zealand



### Purpose of Document

This document is intended to help Designers, Builders and Building Consent Authority (B.C.A.) Building Officials who want to ensure that saveBOARD betterBRACE rigid air barrier lining is specified, installed, and performs correctly as a rigid air barrier lining.

Following the instructions within this document are important to ensure correct product use and the ongoing support of the manufacturer's warranty.

### Designer and Installer Qualification and Skill level

Where saveBOARD betterBRACE is specified / installed, the designer/installers should have the appropriate skills and knowledge of the product and, where necessary, the qualification required by law.

#### **Please Note:**

*The design and Installation of saveBOARD betterBRACE relates to building work that forms part of the primary structure and weathertight envelope of a building which is Restricted Building Work (RBW). RBW must be carried out or supervised by a Licensed Building Practitioner (LBP).*

*It is also necessary to obtain building consent before the commencement of work. Failure to do so is an offence under the Building Act 2004.*

### Technical Support

This document must be read in conjunction with the saveBOARD betterBRACE specification document and Codemark Certification CMNZ70162. Please refer to saveBOARD betterBRACE specifications and details, which are easily downloaded from the saveBOARD website [www.saveBOARD.nz](http://www.saveBOARD.nz)



For product maintenance and warranty requirements, please refer to the guidance on the saveBOARD website <https://www.saveboard.nz/rigid-air-barrier>

saveBOARD provides technical support for the full range of saveBOARD products. By visiting <https://www.saveboard.nz/technical-literature> you can access all the latest information regarding our products, including:

Product Assurance Supplier Statement (PASS), Installation Guide, Certifications.

## Product Information

saveBOARD betterBRACE is a unique structural composite panel made from 100% upcycled materials.

The core of the product is made from shredded and compressed composite packaging, giving the user a sustainable and superior performing product.

The manufacturing process does not involve glues, resins, or other biological or environmentally harmful products. During construction or in-service use, it does not create toxic dust, vapours, or other potentially harmful inhalants Volatile Organic Compounds (V.O.C.'s) or Formaldehydes.

saveBOARD betterBRACE is a semi-vapour permeable<sup>1</sup>, rigid air barrier designed for use with timber or steel framing (thermal break must be used). It is finished with a moisture-resistant fibreglass facer on one side and a paper facing on the interior side.

saveBOARD betterBRACE is manufactured in New Zealand and Australia for exclusive use. Please refer to the saveBOARD Product Assurance Supplier Statement for compliance with relevant performance clauses of the New Building Code.

saveBOARD betterBRACE sheet sizes are as follows:

- 2450mm x 1200mm x 10mm
- 2750mm x 1200mm x 10mm
- 3000mm x 1200mm x 10mm
- Custom cut up to 6000mm (special order, min x 70)

saveBOARD betterBRACE has been manufactured and tested by independent testing laboratories in New Zealand (N.Z.) - Australia (Aus), and the United States (U.S.) and has demonstrated compliance with New Zealand Building Code for specific requirements relating to a rigid air barrier application.

The following accredited laboratories have carried out an independent assessment and additional compliance testing to verify compliance with New Zealand Building Code

Assessment Area - Test	Accredited Organisation	Date - Status
<b>Structure</b> – P21 Bracing Test (Screw & Nail fixings)	Scion (N.Z.)	2020 – Current
<b>Durability</b> - NZBC E2 AS1 Table 23 properties	Scion (NZ)	2022 – Current
<b>Structure</b> - P21 Bracing Test (Nail fixings)	BRANZ (NZ)	2022 – Current
<b>Fire</b> – Material Group 3 assessment – AS 5637.1	Ignis Labs (Aus)	2022 – Current
<b>Internal Moisture</b> NZBC E3 - WUFI Hygrothermal Analysis	Kaizon (NZ)	2022 – Current

\*(Please refer to saveBOARD website for current test certification)

<sup>1</sup> saveBOARD is a semi-permeable Class II vapour retarder as defined by the International Residential Code (IRC).

## Not Perfect

betterBRACE is made from 100% recycled composite packaging, with a fibre glass face. Please note that the surface may look marked, or even mouldy. This appearance is simply the colour in the recycled packaging that can be seen through the fibre glass face. The colour can get embedded into the fibre glass during manufacture when heat and pressure are applied. This does not affect the performance of the product in any way. saveBOARD products also have a dimensional tolerance of + / - 1mm.



## NZBC Building Compliance Approval

saveBOARD betterBRACE has been evaluated as an ALTERNATIVE SOLUTION material through testing to the reference standards in the NZ ACCEPTABLE SOLUTIONS for the following New Zealand Building Code clauses:

**B1 structure** Performance Clauses B1.3.1, B1.3.2, B1.3.3 (b, f, h), B1.3.4

**B2 Durability** Performance Clauses B2.3.1(a); B2.3.2

**E2 External moisture** Performance Clauses E2.3.2 (contributes to), E2.3.5 (contributes to), E2.3.6 (contributes to), E2.3.7

**F2 Hazardous building materials** Performance clauses F2.3.1

**H1 Energy efficiency** Performance Clauses H1.3.1 (b) (contributes to)

## Working safely with saveBOARD

All saveBOARD products are safe to work and live with.

- saveBOARD can be cut, drilled, and sanded in the same manner and methods as most wood-based products.
- saveBOARD products do not contain materials that are known to cause cancer if work-related dust is inhaled.
- saveBOARD cutting activities do not generate harmful dust, but we recommend you always follow Health & Safety best practices to reduce or limit inhalation.

### Safety recommendations for working with saveBOARD betterBRACE

We recommend cutting is completed outside or in a well-ventilated area.

ALWAYS wear Personal Protective Equipment (P.P.E.). We recommend minimum P.P.E. of Safety glasses - Hearing protection – Dusk mask. When working near others, instruct them to also wear P.P.E. Always use the right tool(s), following the manufacturer's safety recommendations.

Refer to saveBOARD Material Safety Data Sheet for further details.

#### Cutting – Hand saw and Power tools

saveBOARD betterBRACE can be cut in the same manner and methods as most wood-based products.

**STEP 1** – Using a standard carpentry pencil, mark the cut line on the saveBOARD betterBRACE  
Hand-Cut - For handsaw cutting, a standard 500mm Handsaw with a > 7 Teeth Per Inch (T.P.I.) is suitable.

**STEP 2** - For accurate cutting, it is always recommended that the cut is made with a power saw running against a fixed straight edge.

Power Cut - For power saw cutting, a circular saw with > 1200w motor fitted with a standard ripping blade > 40 Teeth is suitable.

**Step 3** – Clean up the cut with a sandpaper block/ 80 Grade sandpaper or as required.

\*For all cutting, always follow the tool manufacturer's safety recommendations.

#### Drilling - Hole forming - For smooth, clean-cut circular holes:

saveBOARD betterBRACE can be drilled in the same manner and methods as most wood-based products.

**STEP 1** – Mark the centre of the hole required on the sheet.

**STEP 2** – Using a 3 – 5mm standard drill bit, pre-drill a central 'pilot' hole.

**STEP 3** - Using the pilot hole as a guide, cut the hole with the hole saw that is correct for the hole size required. It is recommended

to use a heavy-duty power drill, but a battery drill with sufficient power can achieve a good result.

**T.I.P.** – Allow the hole saw to cut. Do not apply excessive pressure as this may damage the back of the board upon exit.

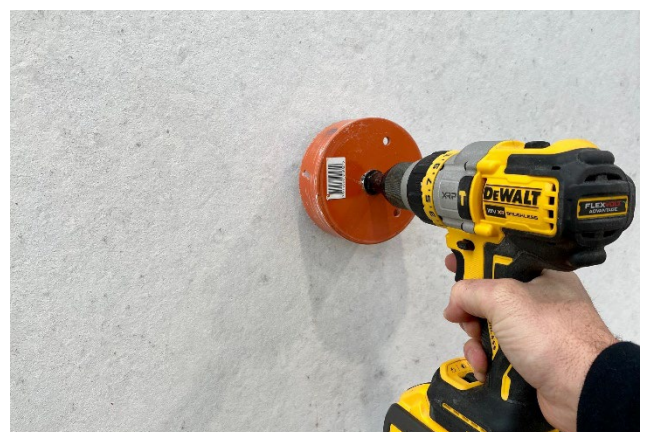

*Always follow the tool manufacturer's safety recommendations.*

## **Sanding**

Clean up cut edges with a sandpaper block /80 Grade Sandpaper or as required.

## **Seal**

All cut edges must be sealed with an acrylic undercoat sealer.

## **Handling and Storage**

Safe handling in transport and storage on-site is essential for worker's safety and protection of saveBOARD betterBRACE.

When manually handling saveBOARD betterBRACE ensure the panels are lifted correctly. For safety, we recommend a minimum of 2 people.

Where multiple pallets are stacked, all storage bearers must align to the ground. For safe working, it is not advisable to stack materials above chest height on-site and materials should always remain restrained to protect against high wind exposure.

**Do not** store betterBRACE outdoors without protective waterproofing. betterBRACE is intended for external use, but whilst laid flat on a pallet water will migrate between the layers making the backing paper wet which will degrade the product. betterBRACE should be stored flat on suitable bearers under protective waterproofing with a minimum of 50mm clearance from the ground and water sources. The spacing between the bearers should be no more than 600mm apart. If not stored correctly claims for damaged product will not be accepted.

It is good to trade practice to allow sheet materials to climatize to the site conditions for 48 hours prior to Installation.

## **Standard Installation**

### **Installation Scope**

saveBOARD betterBRACE is suitable for use as a rigid air barrier for buildings up to and including E.H. wind zone within the scope of NZS 3604 and E2/AS1, not exceeding 10 metres in height for bracing applications, follow the saveBOARD betterBRACE bracing details specified in this installation guide. Bracing with rigid air barriers can only be achieved when fixed directly to the frame. The board must be fixed in accordance with the bracing details of all framing.

saveBOARD betterBRACE must always be fixed directly to the framing, the vertical face joints and bottom edge must be sealed with appropriate tape systems (see recommended tapes).

The cladding systems used over saveBOARD betterBRACE must satisfy the various performance requirements of the NZBC E2 (Accepted or Alternative Solution) saveBOARD betterBRACE is suitable for use behind NZBC E2/AS1 complying cladding systems approved by a B.C.A.

The cladding system must not be directly fixed to saveBOARD betterBRACE and must be installed by incorporating a ventilated cavity E2/AS1 type cladding system.

### **Support Framing**

All support timber framing shall comply with NZS 3604 or comply with the Specific Engineering Design (S.E.D.) requirements. Steel framing by S.E.D.

All frame durability treatments must comply with NZBC B2/AS1. saveBOARD does not recommend board installation (Externally or Internally) on very wet timber framing. It is the builder's responsibility to ensure that framing is confirmed at a moisture content  $\leq 16\%$  before internal linings are applied. This is a saveBOARD warranty requirement.

90 x 45mm minimum timber framing size is the minimum recommended for fixing saveBOARD betterBRACE. It is the designer's responsibility to ensure that the framing and the saveBOARD substrate are suitable for installing the selected cladding.

**Table 1. Structural framing stud set out**

Wind Exposure	Stud Centres (Max)
Up to including H (High)	600mm
VH (Very High)	400mm
EH (Extra High)	400mm

**Vertical Installation and Joints**

All saveBOARD betterBRACE sheets must be installed vertically, with an expansion gap between the sheet edges of 2-4mm required. This includes external and internal vertical corner joints.

All vertical board joints should be fully supported by vertical timber/ metal studs. Any horizontal joints or cut-outs within a sheet should be supported by backing blocks.

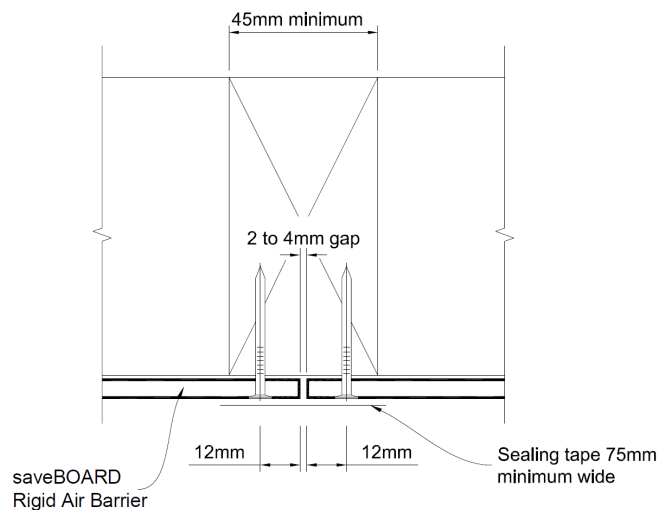

**DIAGRAM 1 – Vertical Board Layout**

The bottom edge of sheets must overhang below the bottom plate by 15 – 20mm. The bottom sheet edge must remain a minimum of 100mm clearance (150mm recommended) to the ground and saveBOARD betterBRACE should not be in contact or exposed to standing water during construction.

**Horizontal Joints**

For two storey buildings (not exceeding 10mtrs) saveBOARD betterBRACE must not be fixed directly to intermediate floor joists. At the intermediate floor level, a horizontal joint detail is required.

Step 1: The lower vertical board should project over the intermediate floor joist to a maximum of 50mm.

Step 2: A continuous Z type flashing must be installed horizontally to the full length of the wall. For wall lengths over 3m the Z flashing must be lapped 50mm and silicone sealed. The Z flashing must provide face covering to the lower sheets to a minimum of 40mm.

Any vertical or internal corners to the horizontal Z flashing must be sealed with appropriate joint tape with a minimum 75mm cover to the corner joint.

When installing the intermediate level boards, a minimum of a 15mm movement gap is required between lower and upper boards. The Z flashing upstand behind the intermediate boards must provide a minimum 30-35mm back cover.

No fixings are allowed in the floor joist or Z flashing area.

The lowest sheet fixing to the upper intermediate boards must be into the intermediate floor subframe bottom plate and stud only.

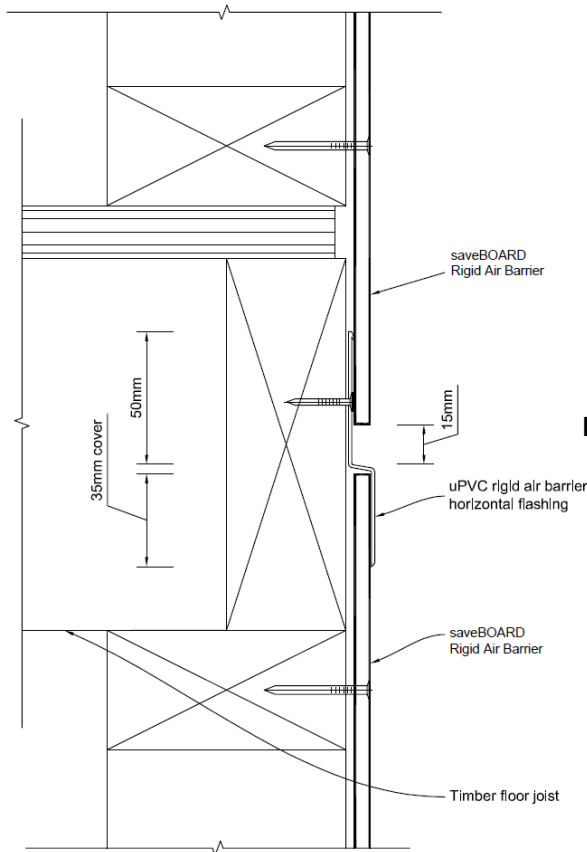

**DIAGRAM 2** – 2 Storey Horizontal Joint detail



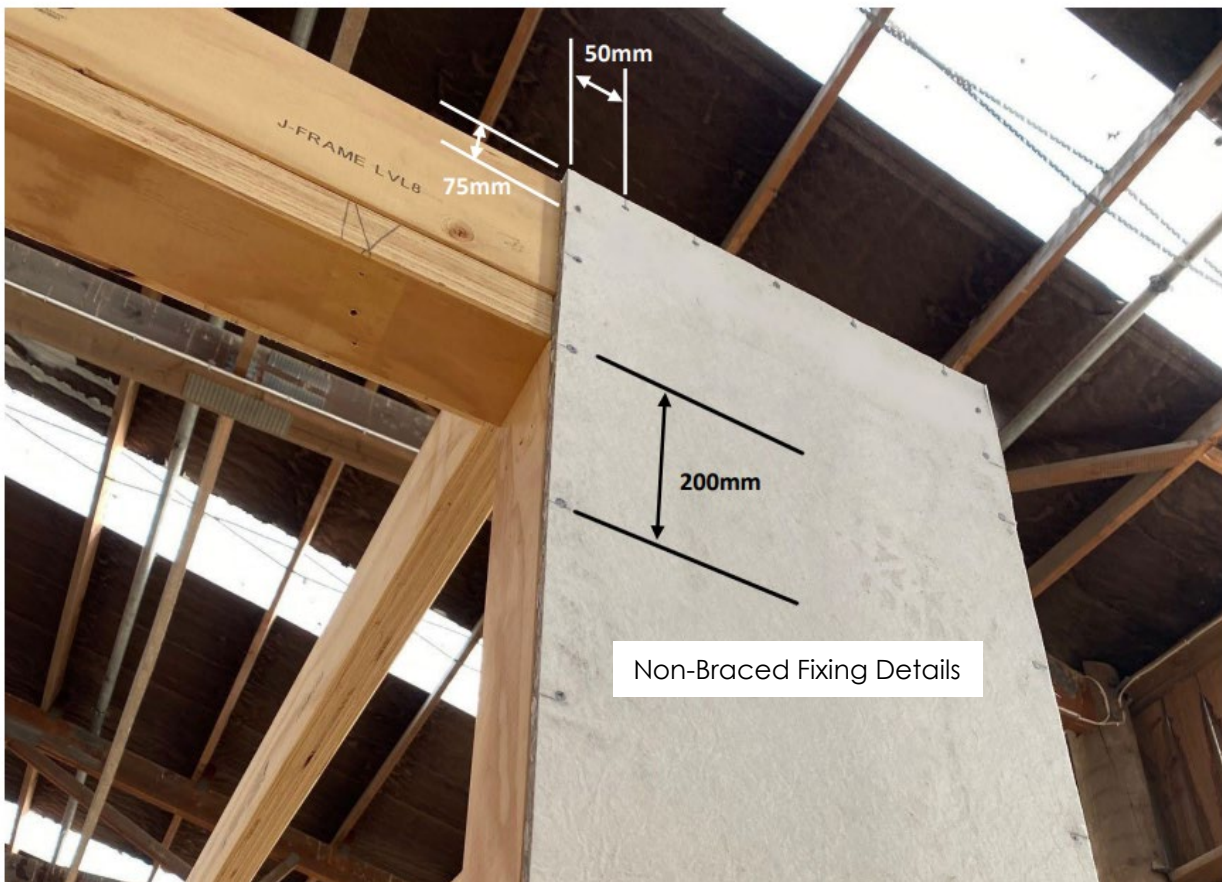

**DIAGRAM 3** – Standard Board Fixings

## saveBOARD betterBRACE fixings

saveBOARD betterBRACE must be installed with its fiberglass side facing out towards the external cladding. The fiberglass applied on the face helps the board to drain the moisture freely over the face and keeps it dry. To retain board integrity, all nail fixings must finish flush with the board surface.

### Bracing and Non-Bracing fixings

saveBOARD betterBRACE can either be fixed with pneumatic nails (gun nails) or hand nails. Tables 2 & 3 below lists the recommended fixing types.

All fixings must have a minimum clearance of 50mm horizontally and vertically from the sheet corners and minimum of 12 mm from the sheet edges.

Nail gun fixings must be of a suitable round head type to provide the minimum hold capacity required.

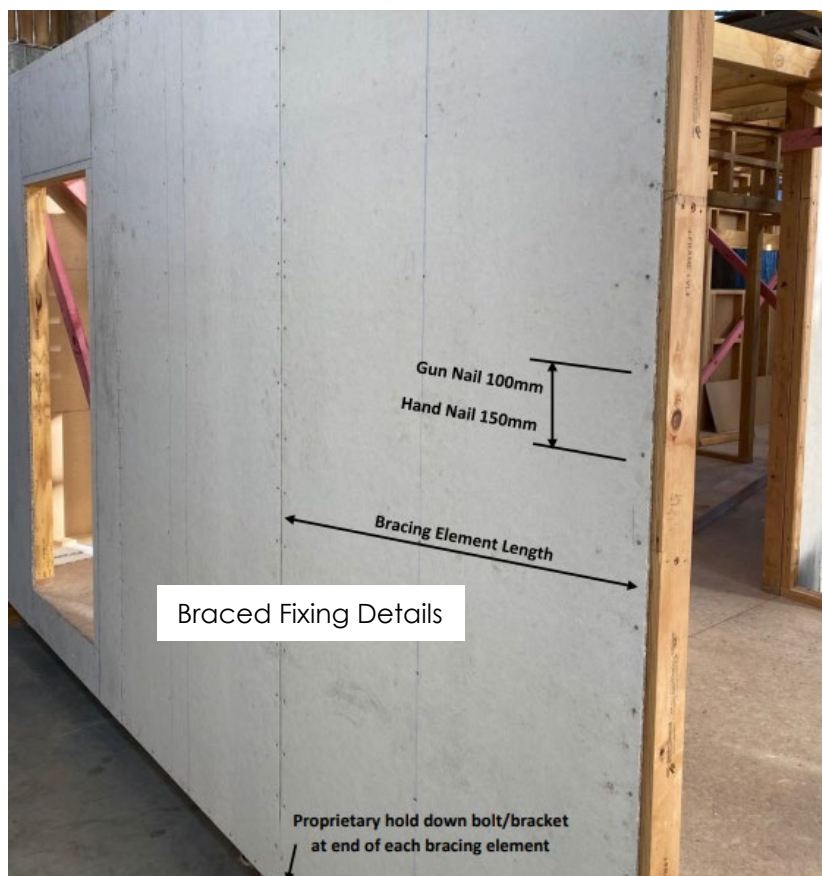

**Table 2. saveBOARD betterBRACE 10mm Fixings (Non-Bracing)**

Type of fixing	Description	Fixing centers (incl intermediate studs)	Frame type
Hand Nail	50 x 2.8mm Galvanized Flat Head Nail	Corner pattern - 50, 200mm horizontal. 75, 200mm vertical	Timber Only
Nail Gun	50 x 2.8mm Galvanized Flat Head Ring Shank Nails	Corner pattern - 50, 200mm horizontal. 75, 200mm vertical	Timber Only

**Table 3. saveBOARD betterBRACE 10mm Fixings (Bracing)**

Type of fixing	Description	Fixing centres (incl intermediate studs)	Frame type
Hand Nail	50 x 2.8mm Galvanized Flat Head Nail	Corner pattern - 50, 150mm horizontal. 75, 150mm vertical	Timber Only
Nail Gun	50 x 2.8mm Galvanized Flat Head Ring Shank Nails	Corner pattern - 50, 100mm horizontal. 75, 100mm vertical	Timber Only



**DIAGRAM 4** – Bracing Board fixings

## Fixing Durability

Structural fixings are a critical component of a building system. To comply with the NZBC B2 Durability requirements, all structural fixings must have the same level of Durability as required for a structural wall system. Tables 2 and 3 list fixings suitable fixings for NZBC Corrosion Zones A-C only.

Description	Concrete Slab (150 BU/m max)		Timber Floor (120 BU/m max)	
	Wind (BU/m)	EQ (BU/m)	Wind (BU/m)	EQ (BU/m)
<b>System 1:</b> saveBOARD - 400mm x 2400mm with GIB Handibrac. Fixing 50 x 2.8mm Galvanized Flat Head Ring Shank Nails	65 BU/m	76 BU/m	65 BU/m	76 BU/m
<b>System 2:</b> saveBOARD - 600mm x 2400mm with GIB Handibrac. Fixing 50 x 2.8mm Galvanized Flat Head Ring Shank Nails	87 BU/m	98 BU/m	87 BU/m	98 BU/m
<b>System 3:</b> saveBOARD - 1200mm x 2400mm with GIB Handibrac. Fixing 50 x 2.8mm Galvanized Flat Head Ring Shank Nails	143 BU/m	150 BU/m (max) 154 BU/m	120 BU/m (max) 143 BU/m	120 BU/m (max) 154 BU/m

It is the designer's responsibility to confirm exposure requirements for individual projects. When such corrosion risks as Sea Spray or Geothermal exposure exist, it will be necessary to increase the fixing Durability to Stainless steel type or equivalent to the satisfaction of the B.C.A.

**Bottom Plate Fixing** Use GIB HandiBrac® hold-down connections at each end of the bracing element. Install in accordance with the installation instructions supplied with the connectors and follow instructions for the recommended fastenings to be used for either concrete or timber floors. Within the length of the bracing element, bottom plates are to be fixed in accordance with the requirements of NZS 3604.

## BRACING DESIGN AND INSTALLATION

saveBOARD betterBRACE may be used as a bracing element with structural timber wall and steel framing systems that comply with New Zealand Building Code

### Scope of use

saveBOARD betterBRACE bracing may be used for;

- New buildings construction; and
- Alterations to existing buildings

For alterations to existing buildings, the designer/ builder must satisfy themselves that the existing subframe/structure is suitable to achieve the desired bracing performance, and the saveBOARD betterBRACE BU/m must be considered indicative only when applied to the existing structure.

### Bracing Design requirements

When specifying saveBOARD betterBRACE as a design bracing element, it is the designer's responsibility to confirm the following site-specific conditions:

- Environmental exposure zone
- Wind zone
- Critical structural design input (Wind and Earthquake loads) as applicable to the wall bracing calculations required
- Structural framing specification requirements
- Suitable durability treatment for structural frames/substrate

- Suitable design and specification for an NZBC compliant cladding and roof system
- All other matters that may affect performance

### Bracing Design Performance Input

saveBOARD betterBRACE Bracing Units (BU/m) comparison

Product	Wind (BU/m)	Earthquake (BU/m)
saveBOARD 10mm	143	154
OSB 8mm	131	107
Cement Board 6mm	125	102
Plywood 7mm	123	139

Based on a 2450 x 1200 Sheet (Nail fixed)

### Specification for Extra High Wind Zone

**Wind zones:** Extra High.

**Wind pressure:** Up to 4.5 kPa U.L.S.

**Substrate structural fixings:** saveBOARD betterBRACE installation must be as per the instructions in this manual. Bracing elements can be achieved effectively by using all current New Zealand Building Code approved mechanical fixing strap, bracket, and hold down systems (Pryda, HandiBrac, Mitek, etc.).

**Substrate framing - timber:** Wall stud spacing must not exceed 400 mm centres for EH Wind Zones as per Table 2 & 3. Prior to internal lining installation, the structural framing moisture content is recommended to be ≤ 16%.

**Substrate framing – steel:** Refer to S.E.D

**Bracing Sheet service penetrations:** Service penetrations holes must not exceed 100mm x 100mm in dimension or 150mm diameter maximum. Penetrations are limited to a maximum of 2 holes per sheet, and multiple penetrations must be a minimum of 750mm apart. Penetrations are not to be located within the top 150mm or bottom 250mm of a bracing sheet.

**Sheet Installation and fixing:** Must be strictly in accordance with the instructions in this guide.

**DIAGRAM 5** – Permitted penetrations in Bracing board.  
Note: All penetrations are to be sealed as per the instructions in this guide.



## JOINT TREATMENT, OPENINGS AND PENETRATIONS

### Over-fix with Synthetic Wall Wrap / Underlay (Mandatory for CodeMark)

betterBRACE must be over-fixed with a synthetic wall underlay within 7 days of installation. Follow underlay manufactures instructions for fixing over a rigid air barrier. When over-fixing a wall underlay joints do not need to be taped but all openings and penetrations must be sealed.

If the underlay is torn or punctured, the damaged area must be patched with flashing tape or additional wrap overlaid (ship lapped) with an overlap of at least 150mm.

Leave window and door openings covered (diagram 6) until the joinery is ready to be installed. Cut the underlay and install flashing tape when the joinery has arrived and is ready to be installed (diagram 7)



**DIAGRAM 6** – leave openings covered



**DIAGRAM 7** – Complete install of underlay when joinery ready to be installed

### Recommended Underlays

- Thermakraft Watergate Plus
- Marshalls Tekton Building Wrap
- Proclima Tescon Extora, Tescon Extoseal and Solitex Extasana Adhero.

### Sealing Cut Edges

It is not necessary to seal saveBOARD betterBRACE cut edges

### Penetrations

Service penetrations (including cabling) must be sealed with a flexible flashing tape providing a minimum of 100mm cover beyond the joint or penetration or a penetration seal.

Service penetrations through saveBOARD betterBRACE and a wall underlay must slope to the outside (Angle of > 5°).

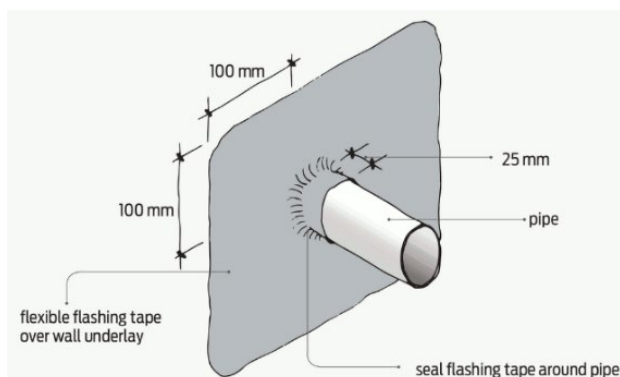

**DIAGRAM 8** – service penetrations

The flashing tape or penetration seal must be installed with a minimum of 25 mm cover projecting around the pipe and 100 mm minimum surface adhesion to the underlay surrounding the penetration.

### Recommended Penetration Seals

Thermakraft OneSeal

Marshalls Trade Seal

### Window /Door Openings

The surface must be free of dust and dirt and must be dry before applying any tape. Use a minimum of 150mm wide tape and refer to the tape manufacturer installation instructions for full details.

Check that the flashing tape being used is compatible with the wall underlay. Extend the flashing tape from the corner in both directions a minimum of 200mm, or further if required, to ensure all exposed framing and the exposed edge of betterBRACE has been covered. As best practice, it is recommended that the full opening is taped.

Use a strip of tape 75mm x 150mm across all corners at a 45 degree angle (butterfly strip). Apply first, under the tape used to seal the opening on the bottom of the opening. On the top corners, apply the butterfly strips over the top sealing tape, pushing the tape in to the corners of the opening. This provides a secondary measure of protection in the corners.



DIAGRAM 9 – bottom butterfly strip



DIAGRAM 10 – top butterfly strip

### Recommended Flashing Tapes

Thermakraft ThermoFlash

Marshalls SuperStick Building Tape

## ADDITIONAL INFORMATION

saveBOARD is committed to a sustainable future. We hold many of the common industry environmental certifications & labels. Ultimately, we can provide transparency to our clients and customers on how we make our saveBOARD products. We have provided relevant additional information below:

### Designing Out Waste

We are focused on several initiatives that design out waste in the built environment, these include:

**💰 Free Return Service:** Send back off-cuts and end-of-life products to be remanufactured into new materials. It costs less than landfill and better for the planet.

**✂️ Cut-to-Length Service:** Only pay for what you need, saving money and reducing on-site labour for cutting sheets.

**♻️ Recycling Manufacturing Waste:** Our side trimmings and reject boards are continuously recycled into new saveBOARD products, its just something we do.

**🌱 Soft Plastics Recycling:** We offer free soft plastics recycling to all our clients, providing a comprehensive site-wide solution not just saveBOARD focused.

### GreenStar Credits

The use of saveBOARD products will earn, or contribute towards earning, Green Star credits in the following Green Star categories:



#### Credit 19: Life Cycle Impacts

saveBOARD are low-carbon products and our

#### Credit 21: Sustainable Products

Only one of following Credits may be claimed per product ie saveBOARD products currently meet 3 out the 4 requirements, but you can only claim against one requirement.

##### 21B: Sustainable content

saveBOARD products contain 99% recycled content.

##### 21C: EPD (Environmental Product Declaration)

Our EPD's are available on our website [www.saveboard.nz](http://www.saveboard.nz)

##### 21D: Third Party

Certified by Eco Choice Aotearoa, and GECA Ecolabel both Level A certifiers.

##### 21E: Stewardship Program

saveBOARD has a Product Steward Program that will qualify for this criterion.

#### Credit 22: Construction and Demolition Waste

Credits for this clause are claimed for the total amount across the project. Soft plastic waste generated on site can be collected and sent to saveBOARD to use in the manufacture of new board. This can be included in the overall total.

## HomeStar (NZ Specific)



Homestar is New Zealand's leading holistic sustainability certification for new home design and construction. The use of saveBOARD products will contribute towards earning Homestar Points in the following categories:

### EN2 Embodied Carbon

For use in your calculations the embodied carbon of saveBOARD products is 0.11 kgCO<sub>2</sub>e/kg

### EN3 Sustainable Materials

Up to 10 points are available where at least 50% of the material content is reused, eco-preferred or responsibly sourced materials. When calculating enter saveBOARD products in category (6), measured in m<sup>2</sup>.

### EN4 Construction Waste Minimisation

#### *Minimising Waste*

saveBOARD products are available cut to length (minimum quantities apply). This will reduce off cuts during installation.

#### *Onsite Sorting*

Soft Plastics can be sorted and returned to saveBOARD to be remanufactured into new board. Ask us for a copy of "Accepted Plastics".

#### *Waste Diversion*

As above, soft plastic waste can be recycled with saveBOARD. Any off cuts can also be returned to be manufactured into new boards.

## Declare Label

Declare is a database of non-toxic, sustainably sourced building products that meet the stringent requirements of the International Living Future Institute's Living Building Challenge.



Declare label is available for all saveBOARD products. Declare is like a nutritional label for building products, offering specifiers, contractors and building users insight into the ingredients used in the manufacture of building products. All saveBOARD products have all achieved Red List Free status.

## Environmental Labels - Eco Choice Aotearoa

Eco Choice Aotearoa is New Zealand's official ecolabel. More than listing sustainable products for green homes or businesses, Eco Choice's Type I ecolabel offers strong, independent proof of environmental best practice for those products and services that bear the mark.

